

INDUSTRIAL DIESEL ENGINE

Kubota Super Mini Series (2-Cylinder)

Z602-E3B

EPA/CARB
TIER
4

Rated Power

12.5 kW @ 3600 rpm



Photograph may show non-standard equipment.

Performance Curves

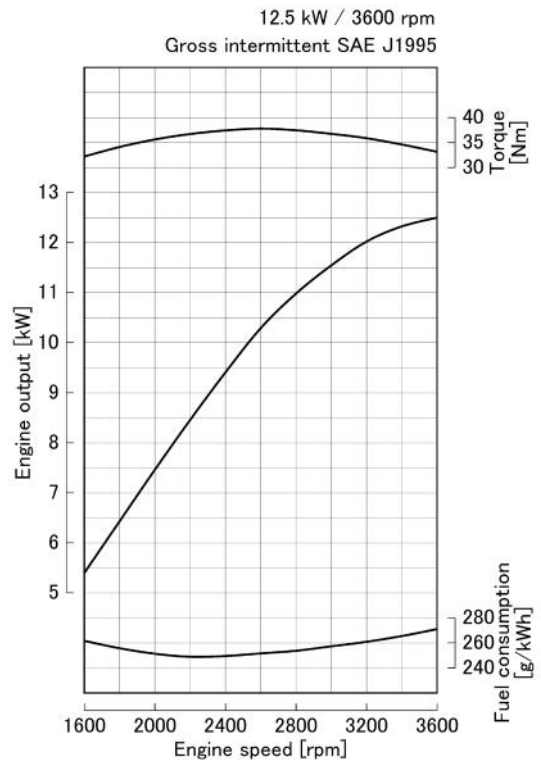

Features and Benefits

Emissions

The Kubota Super Mini Series features compact multi-cylinder liquid cooled industrial diesel engines which comply with EPA / CARB Tier 4 emissions level.

Durable Power

The Kubota Z602 engine is a high-power density engine that delivers maximum output using a 2-cylinder configuration.

By expanding the bore and stroke, Kubota has increased engine displacement while maintaining its compact size. The use of an extended shallow oil pan keeps the engine height lower than that of the Z482, providing a compact engine package.

The cooling water passages between the cylinder bores features Kubota's original casting technology as a countermeasure against the heat load caused by high power density, providing both superior endurance and reliable engine performance.

This engine offers a seamless transition from EPA Tier 2 to EPA Tier 4 by maintaining the same level of performance and physical characteristics.

Clean and Quiet Power

Kubota's original E-TVCS (Three Vortex Combustion System) has been improved for cleaner emissions. The piston recess has been optimized to achieve lower particulate matter (PM) levels at an extremely small size. The half-float valve cover and MoS₂-coated pistons reduce noise levels and decrease vibrations transmitted from the valve area.

For Earth, For Life
Kubota

Z602-E3B

Engine Specifications

Engine model		Z602-E3B
Emission regulation		EPA/CARB Tier 4 level
Type		Vertical, water cooled 4-cycle diesel engine
Cylinders		2
Bore and stroke	mm (in)	72.0 x 73.6 (2.83 x 2.90)
Displacement	L (cu.in)	0.599 (36.55)
Aspiration		Naturally aspirated
Aftertreatment		-
Rated output / speed *1	kW (HP) / rpm	12.5 (16.8) / 3600
Maximum torque / speed *1	Nm (lb-ft) / rpm	37.8 (27.9) / 2600
Combustion system		Indirect injection
Fuel system		In-line pump
Length x Width x Height *2 (without aftertreatment unit)	mm (in)	351 x 401 x 544 (13.8 x 15.8 x 21.4)
Length x Width x Height *3 (with aftertreatment unit)	mm (in)	-
Dry weight *3	kg (lbs)	57 (120)

Specifications are subject to change without notice.
Dimensions and dry weight are according to Kubota's standard specification.
Dimensions and weight depend on completed specifications.

*1: SAE J1995 gross intermittent

*2: Exclude cooling fan and exclude aftertreatment unit

*3: Exclude cooling fan and include aftertreatment unit on engine

Dimensions

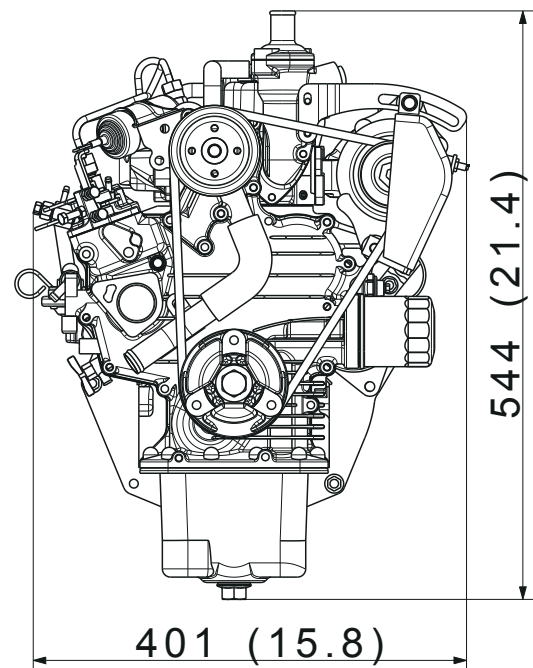
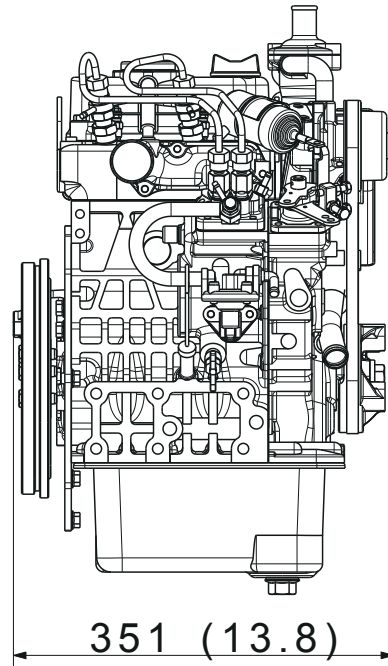

Kubota Corporation

2-47, Shikitsuhigashi 1-chome Naniwa-ku, Osaka, 556-8601 Japan

<https://global.engine.kubota.co.jp/en/>

ASP-Z602-E3B1808-R1-I