

## INDUSTRIAL DIESEL ENGINE

Kubota 03 Series (3-Cylinder)

# D1803-CR-TI-E4B



### Rated Power

**37.0 kW @ 2700 rpm**



Photograph may show non-standard equipment.

### Performance Curves

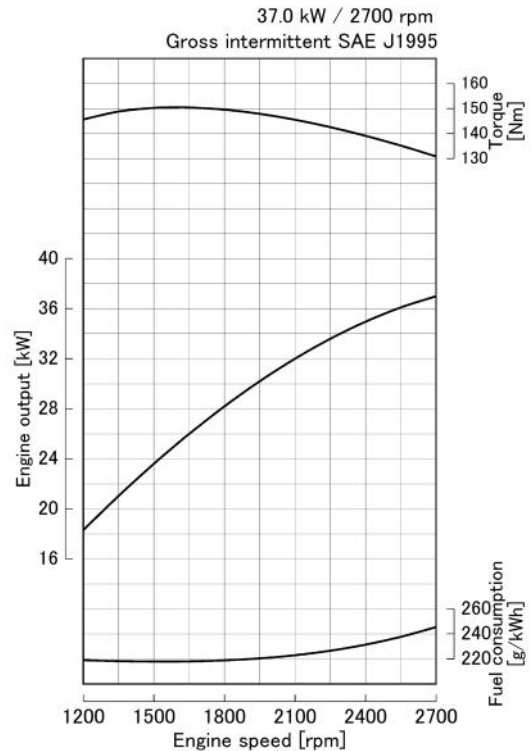

### Features and Benefits

#### Proven Reliability and Technology

The latest technology and strong performance—two things customers expect from Kubota engines. We continue to provide both of these through the pursuit of excellence in three key areas: emissions compliance, progress towards fully electronic-controlled engines, and flexibility in the products and services we provide to customers worldwide.

#### Clean and Quiet Power

A Common Rail System has made it possible to optimize combustion and create a more durable and quieter engine with higher fuel efficiency. This engine model is available with Diesel Oxidation Catalyst (DOC).

#### Emissions Compliance

Meeting rigid emissions regulations can be a challenge for any company. D1803-CR-TI-E4B engines have been designed to comply with stringent regulations: EPA / CARB Tier 4 + EU Stage IIIB. In addition, innovative emissions solutions, such as the use of aftertreatment units, have also been integrated into the 03 Series engines.

#### Flexibility

Flexibility is a must when working with customers in different countries who have different engine needs. Since Kubota 03 Series engines have evolved along every step in meeting the requirements of each EPA Tier, we are able to provide our customers worldwide with engines certified for the appropriate emissions regulations. In addition, we have designed aftertreatment units with minimum impact for easy installation.

#### Trust

The Kubota 03 Series is the ideal solution for your company's global marketing strategy. We continuously strive to meet your needs with the experience and expertise that is your due.

For Earth, For Life  
**Kubota**

# D1803-CR-TI-E4B

## Engine Specifications

<b>Engine model</b>		D1803-CR-TI-E4B
<b>Emission regulation</b>		EPA/CARB Tier 4 + EU Stage IIIB
<b>Type</b>		Vertical, water cooled 4-cycle diesel engine
<b>Cylinders</b>		3
<b>Bore and stroke</b>	mm (in)	87.0 x 102.4 (3.43 x 4.031)
<b>Displacement</b>	L (cu.in)	1.826 (111.4)
<b>Aspiration</b>		Turbocharged + Turbo After Cooler
<b>Aftertreatment</b>		DOC
<b>Rated output / speed</b> *1	kW (HP) / rpm	37.0 (49.6) / 2700
<b>Maximum torque / speed</b> *1	Nm (lb-ft) / rpm	150.5 (111.0) / 1600
<b>Combustion system</b>		Direct injection
<b>Fuel system</b>		Common rail system
<b>Length x Width x Height</b> *2 (without aftertreatment unit)	mm (in)	551 x 536 x 728 (21.7 x 21.1 x 28.7)
<b>Length x Width x Height</b> *3 (with aftertreatment unit)	mm (in)	746 x 536 x 728 (29.4 x 21.1 x 28.7)
<b>Dry weight</b> *3	kg (lbs)	195 (430)

Specifications are subject to change without notice.

DOC: Diesel Oxidation Catalyst

Dimensions and dry weight are according to Kubota's standard specification.

Dimensions and weight depend on completed specifications.

\*1: SAE J1995 gross intermittent

\*2: Exclude cooling fan and exclude aftertreatment unit

\*3: Exclude cooling fan and include aftertreatment unit on engine

## Dimensions

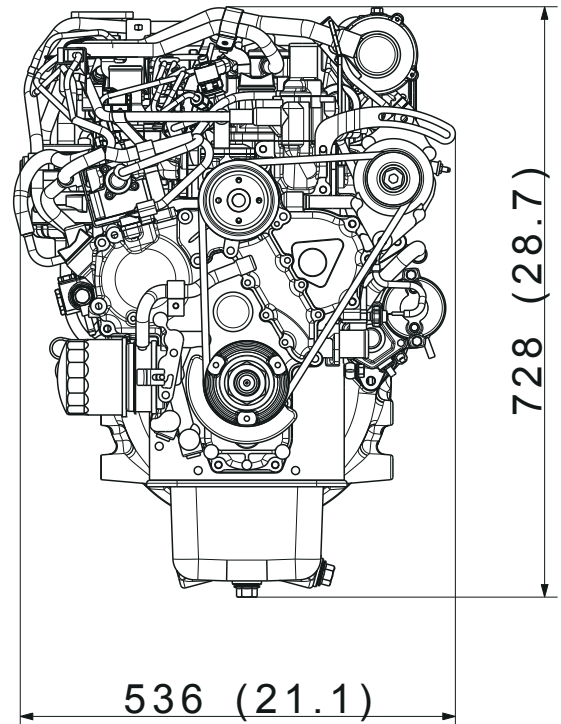
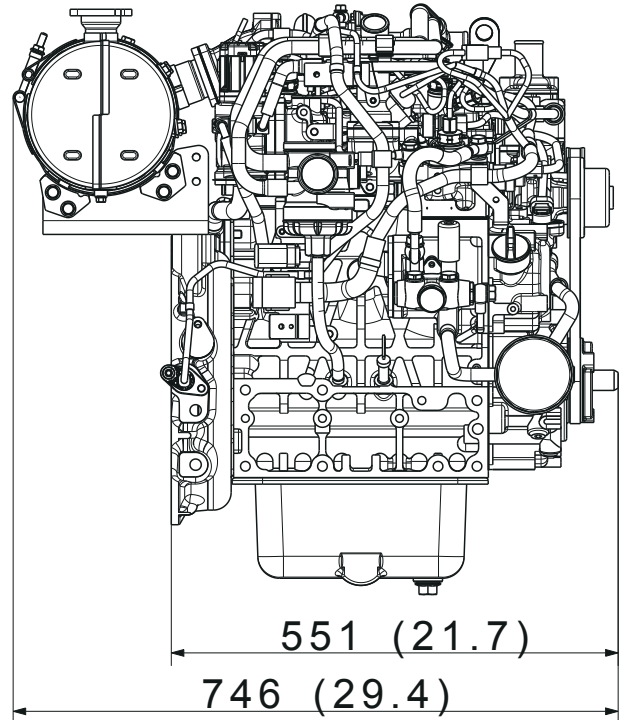

## Kubota Corporation

2-47, Shikitsu Higashi 1-chome Naniwa-ku, Osaka, 556-8601 Japan

<https://global.engine.kubota.co.jp/en/>

ASP-D1803-CR-TI-E4B1808-R1-I