

## DIESEL ENGINE FOR GENERATOR

Kubota 03 Series (3-Cylinder)

# D1703-M-E4-BG2



Stand-by Power

15.0 kW @ 1500 rpm

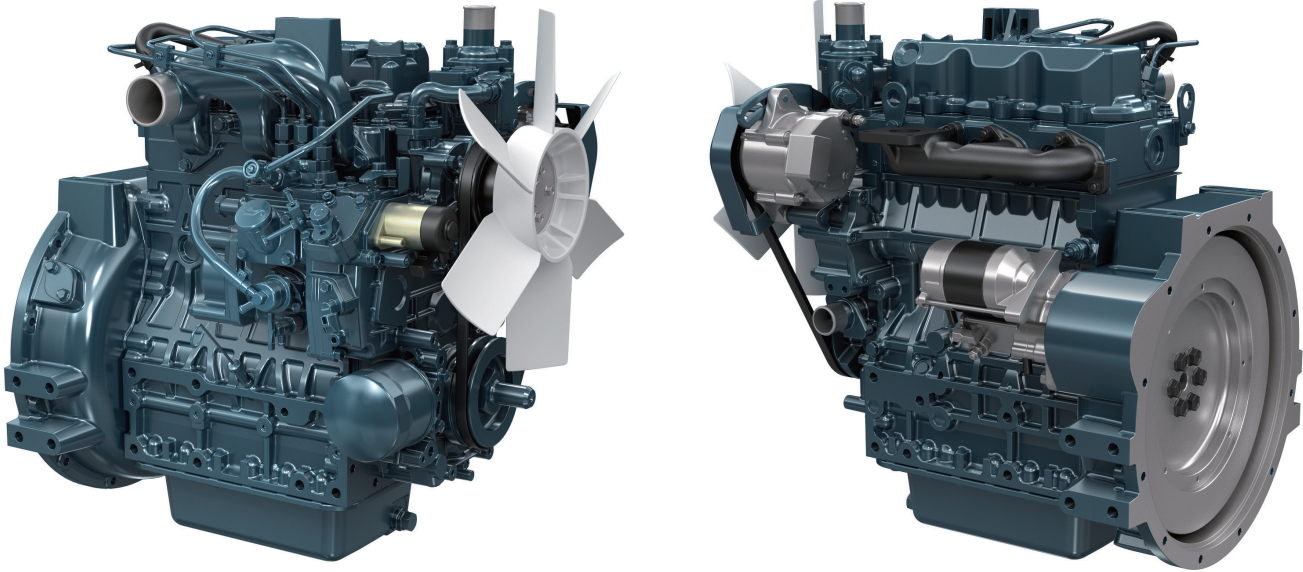

Photograph may show non-standard equipment.

## Features and Benefits

### Durable Power

The Kubota 03-M Series is well known for its industrial applications.

With numerous features such as a built-in solenoid, low fan position, and single-side serviceability, this engine provides excellent performance and flexibility.

The cooling water passages between the cylinder bores features Kubota's original casting technology as a countermeasure against the heat load caused by high power density, providing both superior endurance and reliable engine performance.

### Clean and Quiet Power

The combustion chamber of Kubota's original E-TVCS (Three Vortex Combustion System) and piston recess have been optimized to achieve lower particulate matter (PM) levels.

For Earth, For Life

# D1703-M-E4-BG2

## Engine Specifications

<b>Engine model</b>		D1703-M-E4-BG2
<b>Emission regulation</b>		EU Stage V
<b>Type</b>		Vertical, water cooled 4-cycle IDI diesel engine
<b>Cylinders</b>		3
<b>Bore and Stroke</b>	mm (in)	87.0 × 92.4 (3.43 × 3.64)
<b>Displacement</b>	L (cu.in)	1.647 (100.5)
<b>Aspiration</b>		Naturally aspirated
<b>Aftertreatment</b>		—
<b>Net stand-by power</b> *1	kW (HP) / rpm	15.0 (20.1) / 1500
<b>Net continuous power</b> *1	kW (HP) / rpm	12.8 (17.2) / 1500
<b>Combustion system</b>		Indirect Injection
<b>Fuel system</b>		In-line pump
<b>Length x Width x Height</b> *2 (without aftertreatment unit)	mm (in)	574 × 486 × 643 (22.6 × 19.1 × 25.3)
<b>Dry weight</b> *2	kg (lb)	170 (375)

Specifications are subject to change without prior notice.  
Dimensions and dry weight are according to Kubota's standard specification.  
Dimensions and weight depend on completed specifications.

\*1: SAE J1349

\*2: Exclude cooling fan

## Dimensions

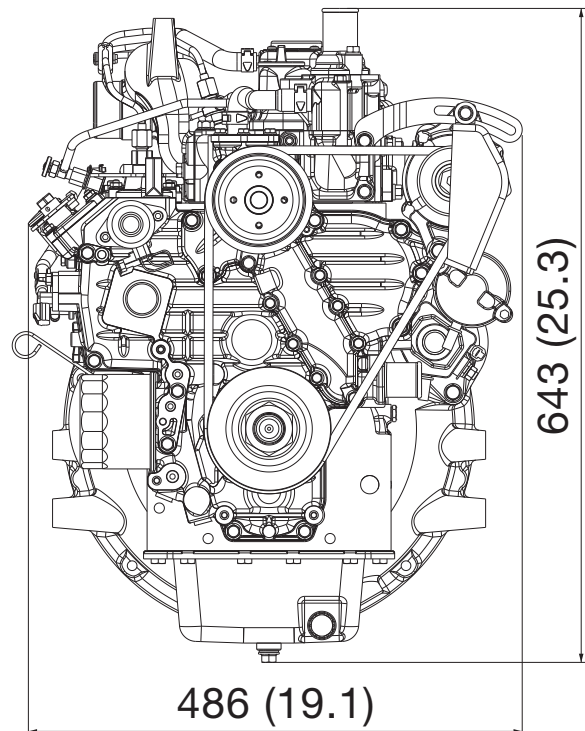
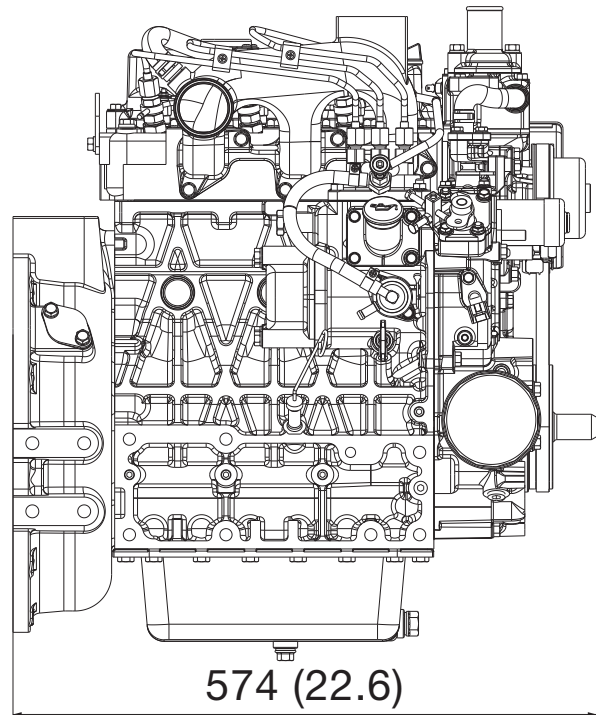

## Kubota Corporation

2-47, Shikitsuhigshi 1-chome Naniwa-ku, Osaka, 556-8601 Japan

<https://global.engine.kubota.co.jp/en/>

ASP-D1703-M-E4-BG22111-N0-STD-208098